

TL17000

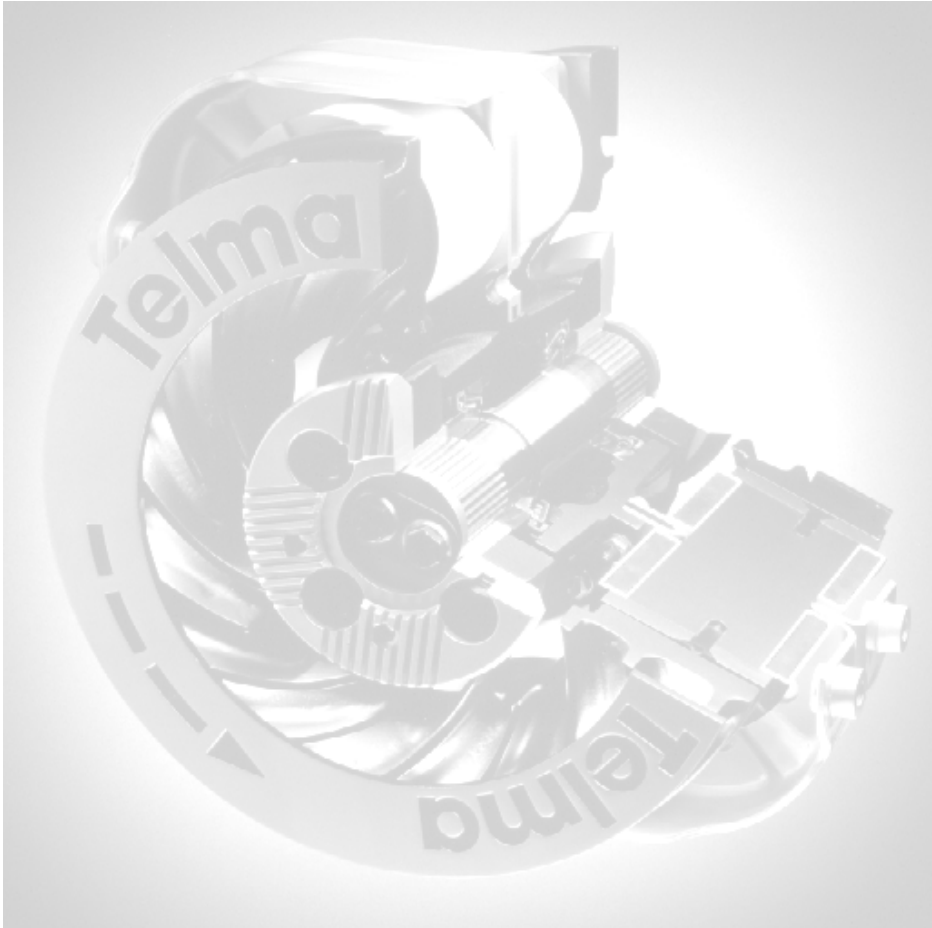

Selection Guide

Telma Retarder Inc.
870 Lively Blvd
Wood Dale
Illinois 60191
Toll Free: 800.797.7714
Tel: 847.593.1098
Fax: 847.593.3592

www.TelmaUSA.com

TABLE OF CONTENTS

1. GENERAL INFORMATION

- 1.1 Comparison Matrix of Secondary Braking Systems
- 1.2 Range and Model Cross Reference

2. SPECIFICATIONS

- 2.1 AE 30-32
- 2.2 AC50-55
- 2.3 AXIAL RANGE
- 2.4 FOCAL RANGE

3. CALCULATIONS

- 3.1 Vehicle Data Worksheet and Torque Factor Calculation
- 3.2 Tire Radius Table
- 3.3 Model Selection and Shaft Torque Limits
- 3.4 Flange Yoke Selection

4. AXIAL UNIVERSAL INSTALLATIONS

- 4.1 Universal Axial Installation Selection
- 4.2 Grouped Universal Axial Kits

5. AXIAL KITS BY APPLICATION

- 5.1 Ford E350 / E450
- 5.2 Ford F350 / F450 / F550 Cab Chassis
- 5.3 Ford F550 for Shuttle Applications
- 5.4 International 3200
- 5.5 Freightliner MB55
- 5.6 Mack with Inside Brackets
- 5.7 Autocar with Inside Brackets

6. FOCAL UNIVERSAL INSTALLATIONS

- 6.1 Universal Focal Installation Selection
- 6.2 Meritor RS145 Single Axle
- 6.3 Meritor RS160-185 Single Axle
- 6.4 Dana 060/090/105 S/D Single Axle
- 6.5 Dana D170/D190 Tandem Axle
- 6.6 Grouped Universal Focal Kits

7. ORDER FORM

8. APPENDIX

1. GENERAL INFORMATION

1.1 COMPARISON MATRIX OF SECONDARY BRAKING SYSTEMS

| Performance Measured | Exhaust Brake | Engine Brake | Hydraulic System | |
|---|--|--|---|---|
| BRAKING HORSEPOWER {% of Rated Engine Horsepower} | 50% | 60% -110% | 110% to 200% Cooling system determines capacity | 110% to 300% |
| BRAKING POWER LIMITATIONS | ENGINE SIZE RPM RATING EXH. VALVE SPRING SIZE | ENGINE SIZE RPM RATING COMPRESSION RATING | UNIT SIZE COOLING SYSTEM CAPACITY | TELMA SIZE |
| ACTIVATION ~ DEACTIVATION RESPONSE TIME | .20 to 2.00 seconds | 100 to 200 milliseconds | 1.60 to 2.25 seconds | 120 milliseconds |
| ABS COMPATIBILITY + Deactivation Time + Progressive Reactivation | .20 to 2.00 seconds NO | 100 to 200 milliseconds NO | 1.60 to 2.25 seconds NO | 60 -100 milliseconds YES |
| MODULATION | TOTAL ON or TOTAL OFF | TOTAL ON or TOTAL OFF | PROGRESSIVE UNEVEN DOWNSHIFT INERTIA | PROGRESSIVE SMOOTH |
| HEAT DISSIPATION | ENGINE COOLING SYSTEM | ENGINE COOLING SYSTEM | TRANSMISSION COOLING SYSTEM ENGINE COOLING SYSTEM | SELF AIR COOLED |
| BRAKING EFFECTIVENESS | NONE IN NEUTRAL or TORQUE CONVERSION. CONSTANTLY VARYING WITH RPM & GEAR CHANGES - DOWNSHIFTING REQUIRED TO MAXIMIZE | NONE IN NEUTRAL or TORQUE CONVERSION. CONSTANTLY VARYING WITH RPM & GEAR CHANGES - DOWNSHIFTING REQUIRED TO MAXIMIZE | LIMITED BRAKING AT LOW AND HIGH VEHICLE SPEEDS. | BRAKING ACTION CONSTANT THROUGHOUT ENTIRE VEHICLE OPERATING SPEED RANGE |
| NOISE | LOW FREQUENCY RUMBLE | LOW FREQUENCY POPPING | ALMOST SILENT | NONE |
| IMPACT ON EQUIPMENT | BRAKE LOADS CARRIED BY TRANSMISSION INTERNAL COMPONENTS | BRAKE LOADS CARRIED BY TRANSMISSION INTERNAL COMPONENTS | BRAKE LOADS CARRIED BY TRANSMISSION INTERNAL COMPONENTS (INPUT UNITS) | NONE |
| WEIGHT | NON FACTOR | NON FACTOR | 110 LBS (INCLUDES COOLER) | FV61-41, 286 LBS |

1.2 RANGE AND MODEL CROSS REFERENCE**

| AXIAL Range | |
|-------------------|-------------------|
| AC Range | AD-AE Range |
| ----- AC 50-55 | AE 30-32 ----- |
| AC 50-65 | AD 50-90 |
| AC 50-80 | AD 50-90 |
| AC 51-00 | AD 50-90 |
| AC 61-25 | AD 61-30 |
| AC 61-35 | AD 61-30 |
| AC 61-60 | AD 61-55 |
| AC 72-00 | AD 72-00 |
| AC 82-45 | AD 72-45 |

| FOCAL Range | |
|----------------|-----------|
| Previous Model | New Model |
| FN 50-85 | ----- |
| FV 61-00 | ----- |
| FV 61-30 | FV 61-40 |
| FV 61-40 | ----- |
| FV 71-70 | FN 71-65 |
| FN 72-00 | FN 71-95 |
| FN 72-20 | ----- |
| FN 72-40 | ----- |

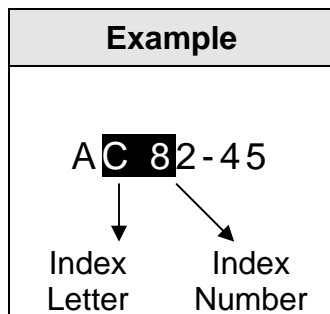

| Index Number | Rotor Diameter |
|--------------|----------------|
| 3 | 251 to 300 mm |
| 5 | 351 to 400 mm |
| 6 | 401 to 450 mm |
| 7 | 450 to 505 mm |
| 8 | 506 to 550 mm |

| Index Letter | |
|-----------------------|--------------------------|
| A X I A L | E → CE Range |
| | C → AC Range |
| | D → AD Range |
| F O C A L | V → Old Generation Rotor |
| | N → New Rotor |

*Note: Not all of these are available for the North American market

2. SPECIFICATIONS

2.1 AE30-32

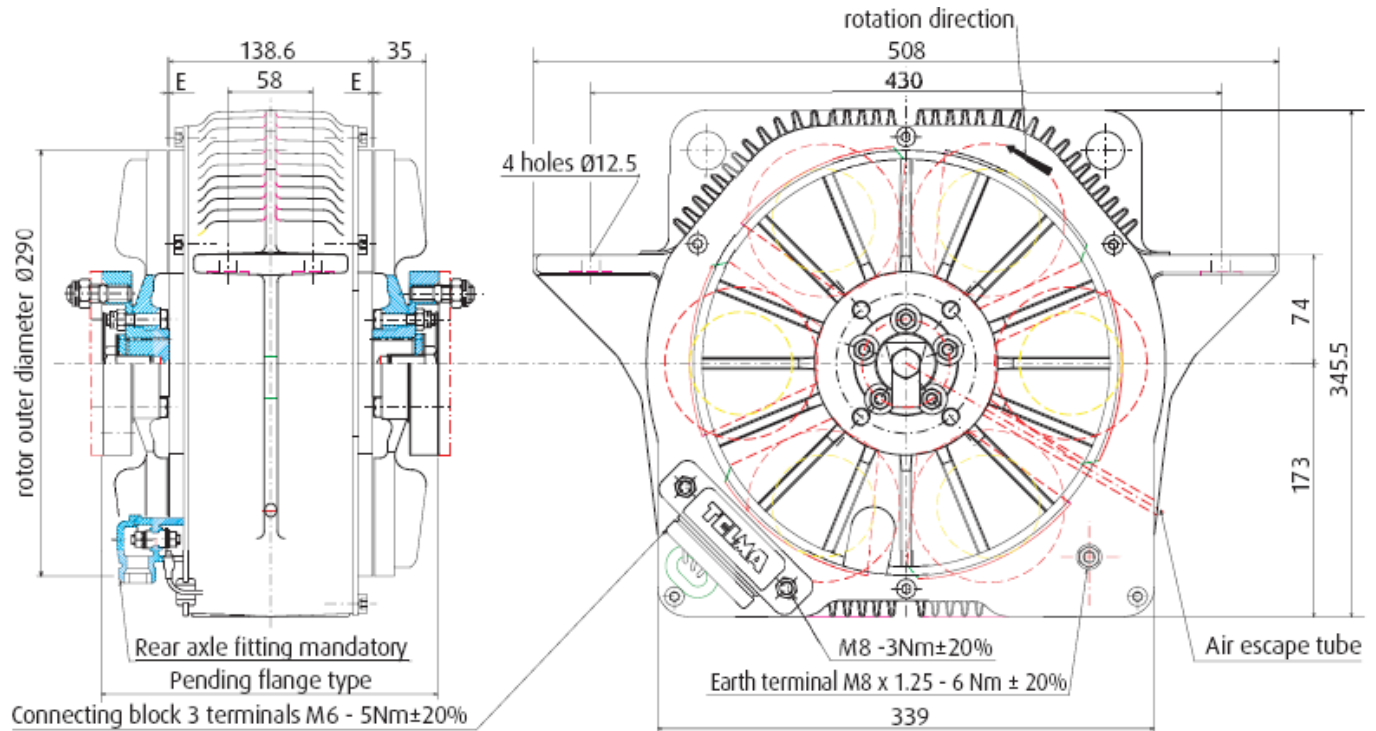

| MODEL | DIMENSIONS | | | HORSE POWER AT 2500 rpm | MAXIMUM BRAKING TORQUE LB.-FT | WEIGHT LBS | AIR GAP INCHES | SHAFT TORQUE LIMIT LB.-FT | AMPS PER STAGE |
|---------|------------|--------|-----------------------|-------------------------|-------------------------------|------------|----------------|---------------------------|----------------|
| | height | width | Length rotor to rotor | | | | | | |
| AE30-32 | 13 5/8 | 13 3/8 | 8 1/4 | 120 | 258 | 179 | 0.039 | 2460 | 16 |

2. SPECIFICATIONS

2.2 AC50-55

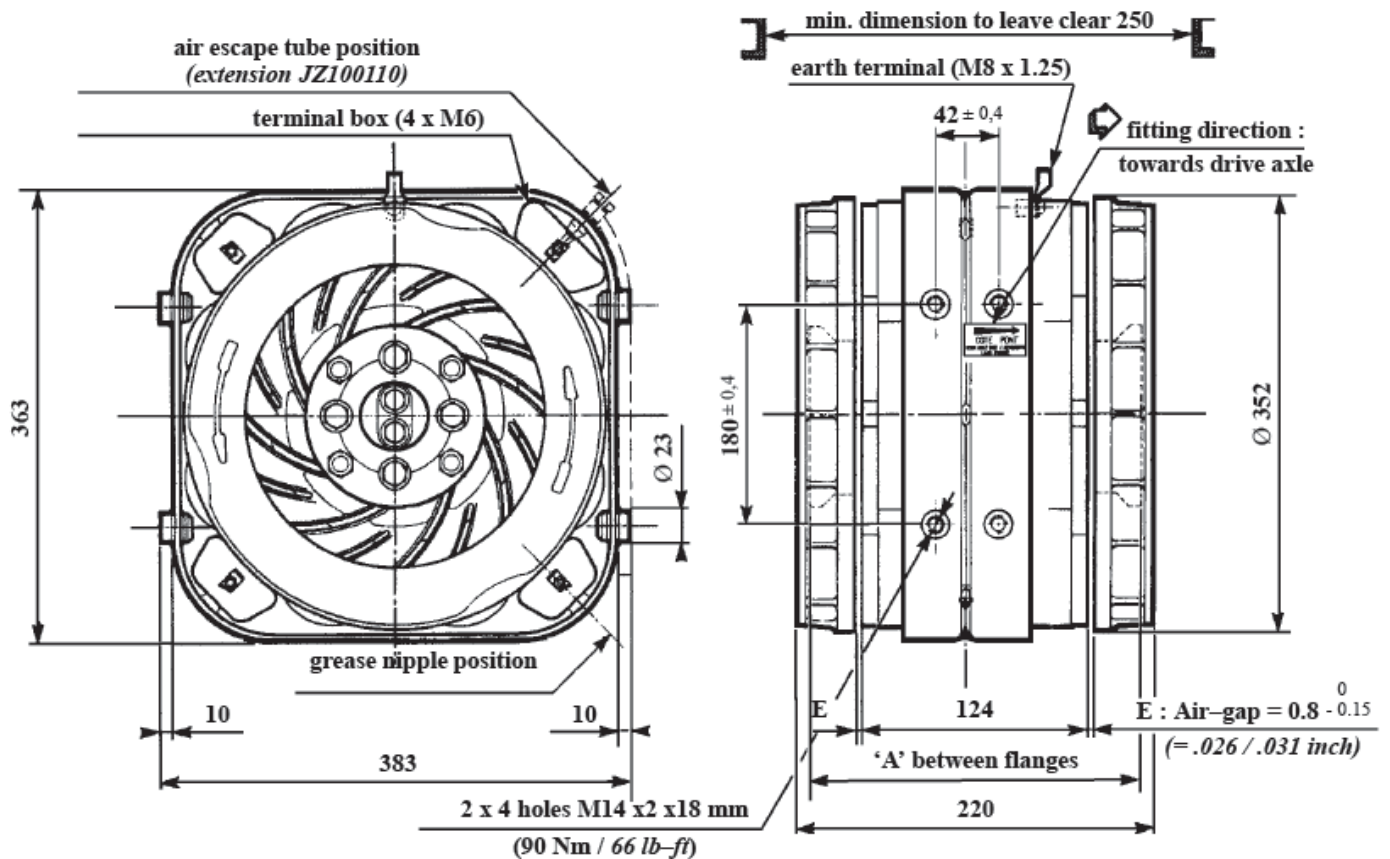

| MODEL | DIMENSIONS | | | HORSE POWER AT 2500 rpm | MAXIMUM BRAKING TORQUE LB.-FT | WEIGHT LBS | AIR GAP INCHES | SHAFT TORQUE LIMIT LB.-FT | AMPS PER STAGE |
|---------|------------|-------|-----------------------|-------------------------|-------------------------------|------------|----------------|---------------------------|----------------|
| | height | width | Length rotor to rotor | | | | | | |
| AC50-55 | 14 1/4 | 15 | 8 11/16 | 140 | 413 | 229 | 0.031 | 6640 | 18 |

2. SPECIFICATIONS

2.3 AD RANGE

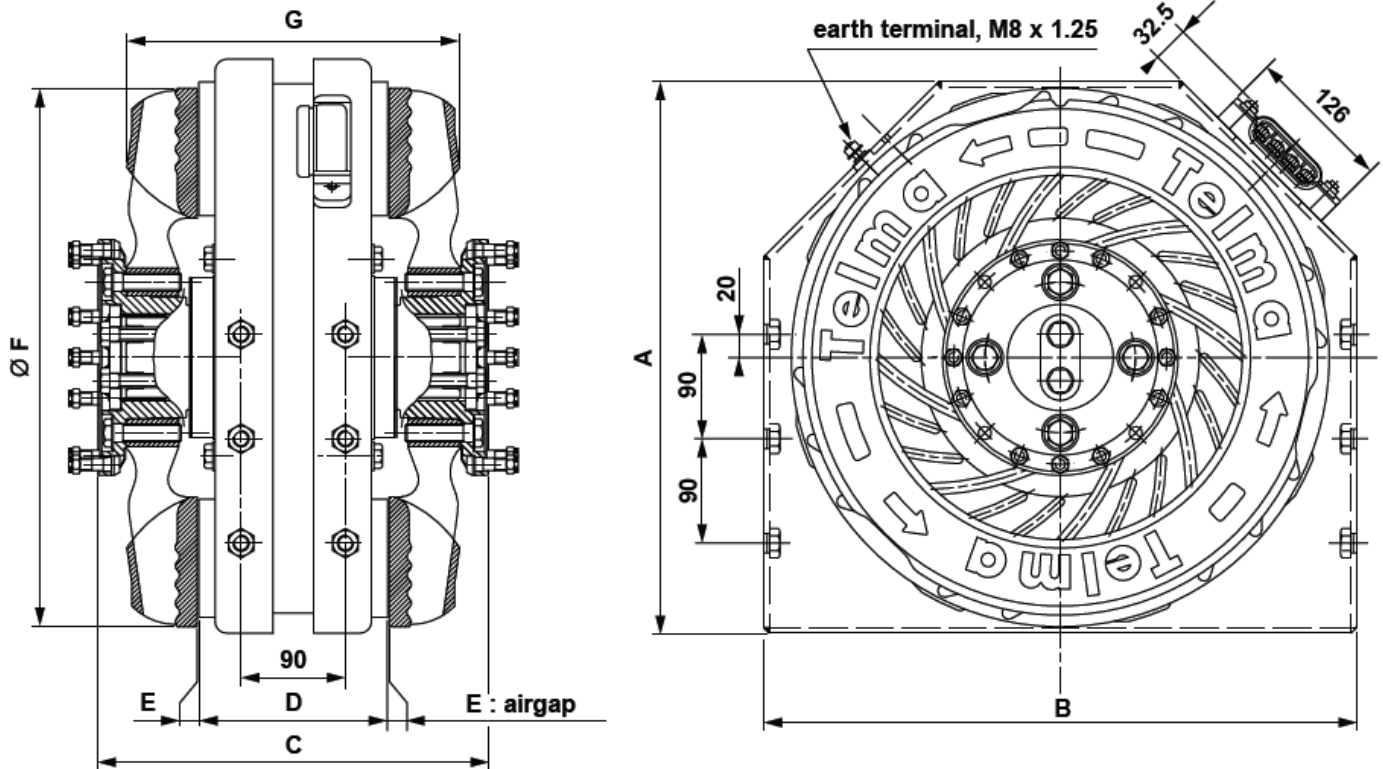

| MODEL | REPLACES | DIMENSIONS | | | HORSE POWER AT 2500 rpm | MAXIMUM BRAKING TORQUE LB.-FT | WEIGHT LBS | AIR GAP INCHES | SHAFT TORQUE LIMIT LB.-FT | AMPS PER STAGE |
|---------|----------|------------|---------|---------|-------------------------|-------------------------------|------------|----------------|---------------------------|----------------|
| | | A | B | G | | | | | | |
| AD50-90 | AC51-00 | 14 1/4 | 15 3/4 | 10 1/4 | 300 | 664 | 276 | 0.039 | 7380 | 48 |
| AD61-30 | AC61-25 | 18 | 19 1/2 | 11 7/16 | 350 | 959 | 419 | 0.039 | 9440 | 33 |
| AD61-55 | AC61-60 | 18 | 19 1/2 | 11 7/16 | 450 | 1180 | 434 | 0.055 | 9440 | 54 |
| AD72-00 | AC72-00 | 18 3/4 | 20 7/16 | 11 1/4 | 600 | 1475 | 507 | 0.055 | 23300 | 60.5 |
| AD72-45 | AC82-45 | 19 1/2 | 20 7/16 | 11 1/2 | 680 | 1770 | 551 | 0.047 | 23300 | 61 |

2. SPECIFICATIONS

2.4 FOCAL RANGE

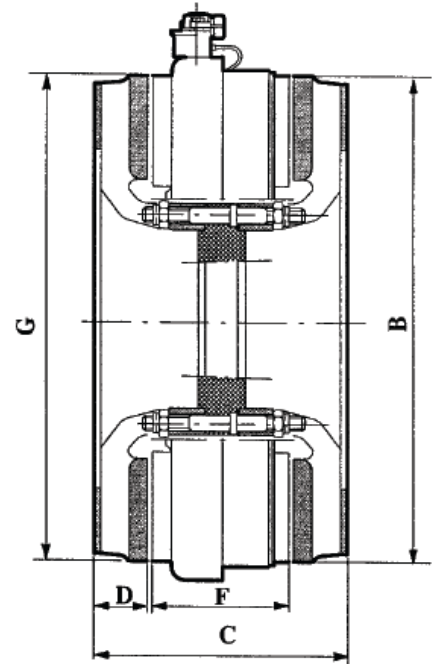
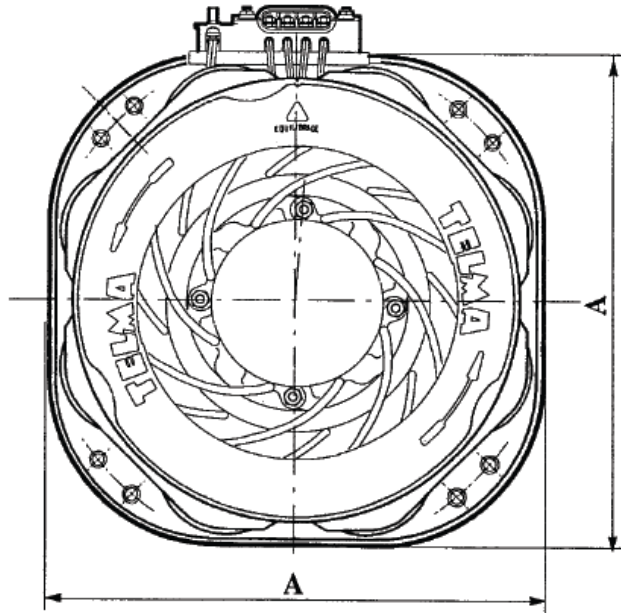

| MODEL | REPLACES | DIMENSIONS INCHES | | | HORSEPOWER AT 2500 rpm | MAXIMUM BRAKING TORQUE LB.-FT | WEIGHT LBS | AIR GAP INCHES | AMPS PER STAGE 12V |
|---------|----------|----------------------|---------|--------|---------------------------|--|---------------|-------------------|-----------------------------|
| | | A | B | C | | | | | |
| FV61-00 | ----- | 18 1/4 | 18 1/4 | 8 1/2 | 263 | 738 | 256 | 0.051 | 37 |
| FV61-40 | ----- | 18 1/4 | 18 1/4 | 8 1/2 | 351 | 1024 | 286 | 0.051 | 52.5 |
| FN71-65 | FV71-70 | 20 5/16 | 20 5/16 | 9 7/16 | 450 | 1180 | 359 | 0.055 | 50 |
| FN71-95 | FN72-00 | 20 5/16 | 20 5/16 | 9 7/16 | 540 | 1401 | 362 | 0.061 | 58.4 |
| FN72-20 | ----- | 20 5/16 | 20 5/16 | 9 7/16 | 585 | 1623 | 381 | 0.061 | 69.4 |
| FN72-40 | ----- | 20 5/16 | 20 5/16 | 9 1/2 | 702 | 1722 | 407 | 0.061 | 75 |

3. CALCULATIONS

3.1 Vehicle Data Worksheet and Torque Factor Calculation

- The following information is needed to calculate the **Torque Factor**

| | |
|--|---|
| GVWR / GCWR (lbs.)* | <input style="width: 100%; height: 20px;" type="text"/> |
| Rear Tire Size | <input style="width: 100%; height: 20px;" type="text"/> |
| Static Loaded Radius (SLR - inches) – see Tire Radius Table | <input style="width: 100%; height: 20px;" type="text"/> |
| Rear axle final drive ratio | <input style="width: 100%; height: 20px;" type="text"/> |

* Gross Vehicle Weight Rating (GVWR) – straight trucks
 Or Gross Combination Weight Rating (GCWR)- tractors or straight trucks with trailers
 Or Final vehicle or combination weight if less than GVWR / GCWR

- Torque Factor =**

| | | | | | |
|--|---|---|---|--|--|
| $\frac{(GVW \text{ or } GCW) \times (\text{Loaded tire radius in inches})}{(\text{Drive Axle Ratio}) \times (88.5)}$ | = | <input style="width: 80%; height: 20px;" type="text"/> | x | <input style="width: 80%; height: 20px;" type="text"/> | |
| | | <input style="width: 80%; height: 20px;" type="text"/> | x | 88.5 | |
| | = | <input style="width: 100%; height: 20px;" type="text"/> | | | |

- For control system kit selection indicate:

| | |
|--|---|
| Type of Brakes (hydraulic or air activated) ----- | <input style="width: 100%; height: 20px;" type="text"/> |
| ABS (yes or no) ----- | <input style="width: 100%; height: 20px;" type="text"/> |
| Type of Telma Control System (hand / foot / dual) ----- | <input style="width: 100%; height: 20px;" type="text"/> |

- For flange yoke selection indicate u-joint series: -----

| |
|---|
| <input style="width: 100%; height: 20px;" type="text"/> |
|---|

- For Axial Series shaft torque limit calculation indicate:

| | |
|---|---|
| Engine maximum torque rating (lb-ft) ----- | <input style="width: 100%; height: 20px;" type="text"/> |
| Transmission lowest gear ratio (first or reverse) ----- | <input style="width: 100%; height: 20px;" type="text"/> |
| Automatic transmission torque converter ratio or 1.0 for manual transmission ----- | <input style="width: 100%; height: 20px;" type="text"/> |

- Transmission make and model (ABS interface): -----**

| |
|---|
| <input style="width: 100%; height: 20px;" type="text"/> |
|---|

- Axle make and model (Focal applications): -----**

| |
|---|
| <input style="width: 100%; height: 20px;" type="text"/> |
|---|

3. CALCULATIONS

3.2 Tire Radius Table

| <i>Tire Size</i> | <i>Radius</i> | <i>Tire Size</i> | <i>Radius</i> | <i>Tire Size</i> | <i>Radius</i> |
|------------------|---------------|------------------|---------------|------------------|---------------|
| 10-22.5 | 19.2 | 11.00R-24.5 | 20.6 | 14.00-24 | 25 |
| 10.00-20 | 19.7 | 11R-22.5 | 19.7 | 14.00-25 | 25.3 |
| 10.00-22 | 20.6 | 11R-24.5 | 20.7 | 14/80R-20 | 19.6 |
| 10.00-24 | 21.6 | 12-22.5 | 20.1 | 15-19.5 | 18.4 |
| 10.00R-20 | 19.7 | 12.00-20 | 21 | 15-22.5 | 19.8 |
| 10.00R-22 | 20.7 | 12.00-24 | 22.9 | 15R-22.5 | 19.6 |
| 10R-22.5 | 19.5 | 12.00R-20 | 20.4 | 16-25 | 28.2 |
| 11-22.5 | 19.7 | 12.00R-22 | 21.4 | 16.5-19.5 | 18.9 |
| 11-24.5 | 20.6 | 12.00R-24 | 22.4 | 16.5-22.5 | 20.5 |
| 11.00-18 | 19.2 | 12R-22.5 | 20.7 | 16.5R-22.5 | 20.1 |
| 11.00-20 | 20.1 | 12R-24.5 | 20.2 | 18-19.5 | 19.5 |
| 11.00-22 | 21.1 | 13.00-20 | 22 | 18-22.5 | 20.9 |
| 11.00-24 | 22 | 13.00R-20 | 21.2 | 18R-22.5 | 21.5 |
| 11.00R-20 | 20.2 | 13/80R-20 | 19.1 | 19.5-19.5 | 20.3 |
| 11.00R-22 | 21 | 14-17.5 | 16.5 | 20.5R-25 | 25.8 |
| 11.00R-24 | 22 | 14.00-20 | 23 | 215/75R-17.5 | 14.2 |
| 215/85R-16 | 14.3 | 7.00-16 | 14.4 | 8.25-18 | 17.2 |
| 21R-25 | 28 | 7.00-20 | 16.9 | 8.25-20 | 18.2 |
| 225/70R-19.5 | 15 | 7.00R-16 | 14.3 | 8.25R-15 | 15.5 |
| 225/75R-16 | 13.6 | 7.50-16 | 15 | 8.25R-17 | 16 |
| 235/80R-22.5 | 17.4 | 7.50-17 | 16 | 8.25R-20 | 18.1 |
| 235/85R-16 | 14.7 | 7.50-18 | 16.4 | 8.75-16.5 | 13.8 |
| 245/70R-19.5 | 15.7 | 7.50-20 | 17.4 | 8R-19.5 | 15.7 |
| 245/75R-22.5 | 17.4 | 7.50R-16 | 14.6 | 9-19.5 | 16.9 |
| 255/70R-22.5 | 17.1 | 7.50R-17 | 15.8 | 9-22.5 | 18.1 |
| 265/75R-22.5 | 18.2 | 7.50R-20 | 17 | 9.00-18 | 18 |
| 275/80R-22.5 | 18.8 | 7.75-15 | 13.1 | 9.00-20 | 19 |
| 275/80R-24.5 | 19.3 | 8-17.5 | 14.9 | 9.00R-20 | 19.1 |
| 285/75R-24.5 | 19.7 | 8-19.5 | 16 | 9R-17.5 | 15.5 |
| 295/75R-22.5 | 19 | 8.00-16.5 | 13.4 | 9R-22.5 | 18.1 |
| 315/75R-22.5 | 19.2 | 8.25-15 | 15.6 | | |
| 315/80R-22.5 | 19.7 | 8.25-17 | 16.7 | | |

3. CALCULATIONS

3.3 Axial Model Selection and Shaft Torque Limits

(Skip this page for focal applications)

Use the table below to choose the model with a Torque Rating as close as possible to the calculated Torque Factor and for the u-joint series of the vehicle.

Example: For a calculated Torque Factor of 1256 and a u-joint series of 1610, the appropriate AXIAL model would be AD61-30 part number BC301158.

Axial Model Selection Table

| Torque Rating | U-Joint Series | Model | Part Number |
|---------------|---|----------|-------------|
| 560 | 1410 (SPL36) / 1480 (SPL55) / 1550 (SPL70) | AC 50-55 | CN201155 |
| 900 | 1480 (SPL55) / 1550 (SPL70) / 1610 / SPL90 / SPL100 | AD 50-90 | BB301158 |
| 1300 | 1480 (SPL55) / 1550 (SPL70) / 1610 / SPL90 / SPL100 | AD 61-30 | BC301158 |
| 1300 | 1610 / SPL90 / 1710 / SPL140 | AD 61-30 | BC301152 |
| 1600 | 1610 / SPL90 / 1710 / SPL140 | AD 61-55 | BD301152 |
| 2000 | 1710 / 1760 / 1810 / SPL140* / SPL170 / SPL250 | AD 72-00 | BE301157 |
| 2400** | 1710 / 1760 / 1810 / SPL140* / SPL170 / SPL250 | AD 72-45 | BH301157 |

- *Flange yoke holes must be enlarged to 7/16" diameter
- **Divide 2400 by the calculated torque factor. If the result is less than 0.70, contact Telma technical support for application approval.
- Divide the torque rating by the calculated torque factor. The result should not exceed 1.2

Note: All part numbers listed are for 12-volt systems. Contact Telma for other applications.

Comparing Driveline Torque to Shaft Limits

Estimate maximum driveline torque by making the following calculation and comparing to shaft torque limits in the table below. The driveline torque calculation should not exceed the Telma shaft torque limits. For applications such as off road applications with special gearing, obtain lowest gear ratios of main transmission, auxiliary transmission or transfer case. Contact Telma for more detailed analysis.

Multiply

Engine Maximum Torque Rating (lb-ft)

X

Transmission lowest gear ratio (5.0 typical)

X

Torque converter ratio (2.0 typical) =

| Model | Shaft Torque Limit (lb-ft) |
|----------|----------------------------|
| AC 50-55 | 6630 |
| AD 50-90 | 7380 |
| AD 61-30 | 9440 |
| AD 61-55 | 9440 |
| AD 72-00 | 23300 |
| AD 72-45 | 23300 |

3. CALCULATIONS

3.4 Flange Yokes for Axial Applications

(Skip this page if you want to choose a focal retarder)

Choose the Flange Yokes

Axial model installations require two flange yokes for each installation. Some Spicer flange yokes needed for applications are available from Telma. Use the figure and table below to identify the driveline series and select the flange yoke for your application.

The flange index refers to the last three digits of the Telma part number.

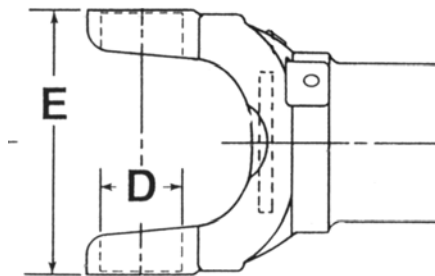

Flange Yoke Selection Table

| Driveline u-joint Series | E Approximate Distance across lugs | D Approximate Bearing diameter | Flange index (last 3 digits of the part number) | Telma flange yoke part number | Spicer flange yoke part number |
|--------------------------|---|---|--|--|---|
| 1350 (SPL30) | 3 7/8" | 1 3/16" | 154 | TIF01082 | 3-2-119 |
| 1410 (SPL36) | 4 7/16" | 1 3/16" | 155 | TIF01080 | 3-2-429 |
| 1480 (SPL55) | 4 7/16" | 1 3/8" | 155 | TIF01081 | 3-2-479 |
| 1480 (SPL55) | 4 7/16" | 1 3/8" | 158 | TIF01086 | 3-2-499 |
| 1550 (SPL70) | 5 1/4" | 1 3/8" | 158 | TIF01088 | 4-2-689 |
| SPL90/SPL100 | 5" | 1 5/8" | 158 | TIF01089 n/a | 90-2-19 |
| SPL90/SPL100 | 5" | 1 5/8" | 152 | n/a | 90-2-69-1 |
| 1610 | 5 5/16" | 1 7/8" | 158 | TIF01091 | 5-2-279 |
| 1610 | 5 5/16" | 1 7/8" | 152 | TIF01090 | 5-2-629 |
| SPL140 | 5" | 1 15/16" | 152/157** | TIF01085 n/a | 140-2-19 |
| 1710 | 6" | 1 15/16" | 152 | TIF01093* | 6-2-749-1 |
| 1710 | 6" | 1 15/16" | 157 | TIF01094* | 6-2-779-1 |
| 1760 | 7" | 1 15/16" | 157 | TIF01095* | 6.3-2-19-1 |
| SPL170 | 6 7/16" | 2 3/16" | 157 | TIF01084 n/a | 170-2-19 |
| 1810 | 7 1/2" | 1 15/16" | 157 | TIF01097* | 6.5-2-329-1 |
| SPL250 | 6 7/16" | 2 3/8" | 157 | TIF01101 n/a | 250-2-19 |

* Half Round flange yoke

** Flange yoke holes must be enlarged to 7/16" diameter for 157 index

4. AXIAL UNIVERSAL INSTALLATIONS

4.1 Universal Installation Selection (Skip this page if you want to choose a focal retarder)

Choose one part number from each category for a complete installation.

step

1. **Telma**

Choose the Telma part number based on the Torque Factor calculation and driveline series

step

2. **Universal Outside Mounting Kit**

Choose mounting kit **TIK03000** for all models except AD50-90.

For AD50-90 choose TIK03.....

Note: If inside mount chassis brackets are necessary notify Telma technical support at time of installation

step

3. **Universal Control System Kit (12V) with Wiring Harness**

Choose one part number based on the application.

Kits below do not include interface. This item must be chosen in step 4 on next page and ordered separately. No interface is needed for TIK10100.

| | |
|-------------------------------------|-----------|
| Hand Control | TIK10100 |
| Hydraulic Brake Foot Control | TIK10103* |
| Air Brake Foot Control | TIK10104 |

IMPORTANT

* **TIK10103 does not contain foot switch mounting brackets. These brackets must be designed and fabricated by the installer.**

Note 1: For dual control: Order hand control switch (part number JL210304) in addition to foot control system kit TIK10103 or TIK10104.

Note 2: When low speed cut-off is desired for transmissions with mechanical speedometer drives; order signal generator kit TIK30101 in addition to the control system kits above.

step

4. **Interface Selection (12V)**

For control system kits TIK10103 and TIK10104 choose one interface part number based on the applications listed below. Hand Control kit TIK10100 does not require an interface.

| Application | Type of Vehicle Speed Signal | Interface Part Number |
|---|--|-----------------------|
| Medium and Heavy Duty Truck with vehicle speed signal (VSS) provided by ECU For Example: Allison 2000 series, MD or HD Series Transmissions Vehicles with VSS provided by Vehicle ECU | High output Square wave Non zero crossing > 3 volts | JC241105 |
| Medium and Heavy Duty Truck equipped with magnetic pickup vehicle speed sensor (VSS) For Example: Allison AT, MT HT Series Transmissions, Manual Transmissions, Light Truck Applications | Low Output Sine wave Zero crossing < 3 volts | JC241103 |

Note 1: If low speed cutoff is desired for hand control, order speed switch P/N JC251100 for high output VSS or JC251101 for low output VSS in addition to TIK10100.

Note 2: Refer to telmausa.com technical website for general wiring diagrams. Contact vehicle manufacturer or Telma Technical Department for specific wiring connections.

step

5. **Flange Yokes**

Choose a flange yoke part number based on the u-joint series and order a quantity of two.

step

6. **Additional Requirements**

Driveline modification: to be provided by the installer

An electrical system upgrade may be necessary, depending on vehicle electrical needs, Telma model used, and vehicle vocation. As an example, a 200-amp alternator and 4 group-31 high cycle batteries are recommended for some refuse applications.

step

7. **Installation Time**

Average install time including Telma mounting and wiring is 16 –20 hours. Refer to Axial Series installation procedure TIL03022 and wiring installation procedure TIL03024 for more details.

4. AXIAL UNIVERSAL INSTALLATIONS

4.2 GROUPED UNIVERSAL AXIAL KITS

step

1. Telma Unit

The Telma unit is included in the kit

Choose the kit below based on the Torque Factor calculation and the shaft torque limits.

step

2. Mounting kit

Mounting kits use universal outside mounting brackets TIB10304, TIB10305, TIB10306

step

3. Controls

Controls included may be hand control or universal foot control for air brakes

Note 1: If low speed cutoff is desired for hand control, order speed switch P/N JC251100 for high output VSS or JC251101 for low output VSS in addition to TIK10100.

Note 2: Refer to telmausa.com technical website for general wiring diagrams.

Contact vehicle manufacturer or Telma Technical Department for specific wiring connections.

step

4. Transmission

Telma ABS interface JC241105 is included with the foot control kits.

JC241105 is designed for use with Allison transmission and other high output speed signals.

Caution: Some manual transmission applications with low output tail shaft mounted speed sensor require JC241103

step

5. U-joint size

Two flange yokes are included in the kit.

Choose a kit below based on the flange yokes needed.

Choose a kit from the table below based on the items mentioned above.

| Torque Rating | Telma Model | Controls | U-Joint Series | Transmission | Brakes Air / Hyd | Part Number |
|---------------|-------------|----------|----------------|--------------|------------------|-------------|
| 1300 | AD 61-30 | foot | 1710 | Allison | Air | TBD |
| 1600 | AD 61-55 | hand | 1710 | Allison | Air / Hyd | TIK10201 |
| 1600 | AD 61-55 | foot | 1710 | Allison | Air | TBD |
| 2000 | AD 72-00 | hand | 1710 | Allison | Air / Hyd | TIK13090 |
| 2000 | AD72-00 | foot | 1710 | Allison | Air | TIK13094 |
| 2000 | AD72-00 | foot | 1760 | Allison | Air | TIK13095 |
| 2000 | AD72-00 | foot | 1810 | Allison | Air | TIK13096 |
| 2450 | AD72-45 | foot | 1710 | Allison | Air | TIK13084 |
| 2450 | AD72-45 | foot | 1760 | Allison | Air | TIK13085 |
| 2450 | AD72-45 | foot | 1810 | Allison | Air | TIK13087 |

5. AXIAL KITS BY APPLICATION

5.1 Ford Econoline Cutaway

2009 and beyond Ford Econoline Cutaway chassis with dual rear wheels

step **1. Installation Kit (includes Telma model AC50-55 / p/n CN201155)**

E350 and E450 all wheelbases

↳ Order installation kit part number – **TIK10676**

Note 1: This kit includes Telma model AC50-55 / part number CN201155 and complete wiring harness

Note 2: This kit does not include drivelines or flange yokes

step **2. Flange Yokes**

↳ Order 1410 flange yokes for 155 Telma flange index (quantity of 2)
Telma part number TIF01080 from Telma
or
Spicer part number 3-2-429 from your drive shaft modifier

step **3. Additional Requirements**

Driveline modification: to be provided by the installer

step **4. Installation Time**

Average install time including Telma mounting and wiring is 8 –10 hours for a chassis without a body. Refer to installation procedure TL113005 for more details.

5. AXIAL KITS BY APPLICATION

5.2 F Super Duty Cab Chassis (except shuttle)

F 350/450/550 from model year 2008

step

1. Telma

F350/450/550 all wheelbases

↳ Choose Telma part number - **CN201155**

step

2. Installation kit

F350/450/550 all wheelbases

↳ Order installation kit part number – **TIK10674**

Note 1: This kit includes wiring harness and foot switch brackets for 2008 and newer chassis

Note 2: This kit does not include retarder, drivelines or flange yokes

step

3. Foot Switch Brackets

The installation kit includes foot switch brackets for 2008 and newer chassis. For older chassis choose pedal bracket, and foot switch bracket from the table below.

| Chassis | Pedal Bracket | Foot Switch Bracket |
|------------------|---------------|---------------------|
| 1996 and earlier | TIB05011 | TIB05026 |
| 1997-1998 | TIB05011 | TIB05024 |
| 1999-2007 | TIB05041 | TIB05040 |
| 2008-2010 | included | TIB05051 |

NOTE: Adjustable brake pedal (if equipped) must be disabled for Telma applications

step

4. Flange Yokes

Choose a flange yoke part number based on u-joint series and order a quantity of two.

For F350 with 1410 u-joints choose Telma part number TIF01080 (Spicer p/n 3-2-429)

For F450/F550 with 1480 u-joints choose Telma part number TIF01081 (Spicer p/n 3-2-479)

step

5. Additional Requirements

Driveline modification: to be provided by the installer

step

6. Installation Time

Average install time including Telma mounting and wiring is 8 –10 hours

5. AXIAL KITS BY APPLICATION

5.3 Ford F550 for Shuttle Applications

F550 from model year 2008

step

1. Installation kit (includes Telma model AD50-90 / p/n BB301158)

F550

→ Order installation kit part number – **TIK10675**

Note 1: This kit includes Telma model AD50-90 (p/n BB301158), wiring harness and foot switch brackets for 2008 and newer chassis

Note 2: This kit does not include drivelines or flange yokes

step

2. Foot Switch Brackets

The installation kit includes foot switch brackets for 2008 and newer chassis. For older chassis choose pedal bracket, and foot switch bracket from the table below.

| Chassis | Pedal Bracket | Foot Switch Bracket |
|------------------|---------------|---------------------|
| 1996 and earlier | TIB05011 | TIB05026 |
| 1997-1998 | TIB05011 | TIB05024 |
| 1999-2007 | TIB05041 | TIB05040 |
| 2008-2010 | included | TIB05051 |

NOTE: Adjustable brake pedal (if equipped) must be disabled for Telma applications

step

3. Flange Yokes

Order a quantity of 2 flange yokes for 1480 u-joints / 158 Telma flange index
 Telma part number TIF01086
 Spicer part number 3-2-499

step

4. Additional Requirements

Driveline modification: to be provided by the installer

step

5. Installation Time

Average install time including Telma mounting and wiring is 8 –10 hours

5. AXIAL KITS BY APPLICATION

5.4 Navistar 4300/3200

step 1. Installation kit

↳ Order installation kit part number –
TIK11203 for hydraulic brakes
TIK11204* for air brakes and 1710 u-joints

Note 1: These kits include retarder, flange yokes, wiring harness, and foot switch brackets (hydraulic brakes)

Note 2: TIK11203 includes AD50-90, TIK11024 includes AD61-30

Note 2: these kits do not include drivelines

*This kit may not be available. Refer to appendix for alternatives

step 2. Flange Yokes

Hydraulic brake chassis with SPL90 driveline

International 3200 is equipped with SPL90 u-joint series.

SPL90 flange yokes are not always available.

1610 flange yokes are supplied in the kit to be used at each side of the retarder.

Air Brake chassis with 1710 driveline

1710 flange yokes are included in the kit

step 3. Additional Requirements

Driveline modification: to be provided by the installer

step 4. Installation Time

Average install time including Telma mounting and wiring is 8 –10 hours

5. AXIAL KITS BY APPLICATION

5.5 Freightliner MB55

step

1. Installation kit

- ↳ Order installation kit part number
TIK10905 for hydraulic brakes / 1550 u-joints
TIK10906 for air brakes / 1550 u-joints

Note 1: These kits include AD50-90 retarder, 1550 flange yokes, wiring harness, and foot switch brackets or pressure switch manifold
 Note 2: These kits do not include drivelines

step

2. Additional Requirements

Driveline modification: to be provided by the installer

step

3. Installation Time

Average install time including Telma mounting and wiring is 16 –20 hours

5.6 Mack with inside chassis brackets

step

1. Telma Unit

Telma model AD72-45 is included in the kit

step

2. Mounting kit

Mounting kits use brackets TIB06000 and TIB05043

step

3. Controls

Universal foot control for air brakes is included

Note: Refer to www.telmausa.com technical website for general wiring diagrams.
 Contact vehicle manufacturer or Telma Technical Department for specific wiring connections.

step

4. Transmission

Telma ABS interface JC241105 is included with the foot control kits.

JC241105 is designed for use with Allison transmission and other high output speed signals.

Caution: Some manual transmission applications with low output tail shaft mounted speed sensor require JC241103

step

5. U-joint size

Two flange yokes are included in the kit.
 Choose a kit based on the flange yokes needed.

| Driveline Series | Kit part number |
|------------------|-----------------|
| 1710 | TBD |
| 1760 | TBD |
| 1810 | TBD |

5. AXIAL KITS BY APPLICATION

5.7 Autocar with inside chassis brackets

- step* **1. Telma Unit**
Telma model AD72-45 is included in the kit
- step* **2. Mounting kit**
Mounting kits use brackets TIB06000 and TIB05044
- step* **3. Controls**
Universal foot control for air brakes is included
Note: Refer to www.telmausa.com technical website for general wiring diagrams.
Contact vehicle manufacturer or Telma Technical Department for specific wiring connections.
- step* **4. Transmission**
Telma ABS interface JC241105 is included with the foot control kits.
JC241105 is designed for use with Allison transmission and other high output speed signals.
Caution: Some manual transmission applications with low output tail shaft mounted speed sensor require JC241103
- step* **5. U-joint size**
Two flange yokes are included in the kit.
Choose a kit based on the flange yokes needed.

| Driveline Series | Kit part number |
|------------------|-----------------|
| 1710 | TBD |
| 1760 | TBD |
| 1810 | TBD |

6. FOCAL UNIVERSAL INSTALLATIONS

6.1 Universal Focal Installation Selection

step **1. Telma** →
Choose the Telma from the table based on the Torque Factor calculation.

| Torque Rating | Model | Telma 12V Part Number Equipped with Rotor Spacer |
|---------------|---------|--|
| 1000 | FV61-00 | FU831310 |
| 1400 | FV61-40 | FJ791310 |
| 1600 | FN71-65 | DV311279 |
| 1900 | FN71-95 | DU311279 |
| 2200 | FN72-20 | DJ311279 |
| 2400 | FN72-40 | DK311279 |

step **2. Focal Mounting Kit**
Choose a mounting kit based on the Telma model chosen and the axle models in sections 6.2, 6.3, 6.4, and 6.5.

step **3. Rent or Buy the Telma Spot Facing Tool**

The pinion cage of the axle must be spot faced before the Telma can be installed. Spot facing is a simple procedure to machine the surface of the pinion cage bolt holes. This avoids the need for a special pinion cage. A tool and procedure to perform this operation can be rented or purchased from Telma. Use the table below for correct Spot Face Tool kits. Contact Telma technical department for more details.

| Axle Make/Model | Kit Includes Basic Tool and | RENT Spot Face Tool P/N | BUY Spot Face Tool P/N |
|-------------------------|------------------------------------|-------------------------|------------------------|
| Meritor RS/RD/RP145/160 | 1 3/16" Counterbore 1/2" Pilot | TIR04000 | TIT04000 |
| Dana 105S | 1 1/2" Counterbore 3/4" Pilot | TIR04001 | TIT04001 |
| Dana 090S | 1 3/8" Counterbore 5/8" Pilot | TIR04002 | TIT04002 |
| Dana 060S | 1 3/16" Counterbore 9/16" Pilot | TIR04003 | TIT04003 |

step **4. Flange Yokes** →
Choose only one of the flange yokes from the table below.

| Driveline Series | Flange Yoke Part Number |
|------------------|-------------------------|
| 1610 | VB107389 |
| 1710 | VB107149 |
| 1760 | VB107793 |
| 1810 | VB107148 |

step **5. Universal Control System kit (12V)**
Choose one part number based on the application from the table below.

Kits below do not include the interface. The interface must be chosen in step 7 and ordered separately.

IMPORTANT

* TIK10103 does not contain foot switch mounting brackets. These brackets must be designed and fabricated by the installer.

| | |
|------------------------------|-----------|
| Hand Control | TIK10100 |
| Hydraulic Brake Foot Control | TIK10103* |
| Air Brake Foot Control | TIK10104 |

Note 1: For dual control: Order hand control switch (part number JL210304) in addition to foot control system kit.

Note 2: When low speed cut-off is desired for transmissions with mechanical speedometer drives; order signal generator kit TIK30101 in addition to the control system kits above.

6. FOCAL UNIVERSAL INSTALLATIONS

6.1 Universal Focal Installation Selection *(continued)*

step **6. Interface Selection (12V)**

For control system kits TIK10103 and TIK10104 choose one interface part number based on the applications listed below. Hand Control kit TIK10100 does not require an interface.

| Application | Type of Vehicle Speed Signal | Interface Part Number |
|---|--|-----------------------|
| Medium and Heavy Duty Truck with vehicle speed signal (VSS) provided by ECU. For Example: Allison 2000 series, MD or HD Series Transmissions Vehicles with VSS provided by Vehicle ECU | High output Square wave Non zero crossing > 3 volts | JC241105 |
| Medium and Heavy Duty Truck equipped with magnetic pickup vehicle speed sensor (VSS). For Example: Allison AT, MT HT Series Transmissions, Manual Transmissions, Light Truck Applications | Low Output Sine wave Zero crossing < 3 volts | JC241103 |

Note 1: In the case of dual control, select interface module based on the foot control system.

Note 2: Refer to Telma Service Manual for general wiring diagrams.

Contact vehicle manufacturer or Telma Technical Department for specific wiring connections.

Additional Requirements: Driveline modification: to be provided by the installer

Installation Time: Average install time including retarder mounting and wiring is 8 –12 hours.

6. FOCAL UNIVERSAL INSTALLATIONS

6.2 Meritor RS145 Single Axle

Focal Mounting Kit

Choose a mounting kit from the table below based on the Telma model chosen and the axle. Refer to section 6.1 Universal Focal Installation for other items needed.

| Differential Assembly Number | Differential Rough Casting Number | Pinion Cage Outside Diameter | Axle Ratio | Driver Controlled Differential Lock (DCDL) | Telma Model | Mounting Kit Part Number |
|------------------------------|-----------------------------------|------------------------------|------------|--|-------------------------------|--------------------------|
| A2 3200-S-1865 | 3200-R-1864 | 8.5" | 3.42-7.17 | NO | FV61-00 FV61-40 | TIK02323 |
| A2 3200-A-1873 | | | | | FN71-65 FN71-95 | TBD |
| A2 3200-L-1676 | 3200-K-1675 | 9.65" | 2.64-7.17 | NO | FV61-00 FV61-40 | TIK02324 |
| A2 3200-U-1919 | | | | | FN71-65 FN71-95 FN72-40 | TBD |
| A2 3200-G-1879 | 3200-F-1878 | | | YES | | |
| A2 3200-F-1904 | | | | | | |

This kit contains the stator carrier, companion flange and the necessary hardware to mount the Telma focal to the axle.

6.3 Meritor RS160-185 Single Axle

Focal Mounting Kit

Choose a mounting kit from the table below based on the Telma model chosen and the axle. Refer to section 6.1 Universal Focal Installation for other items needed.

step

1. Focal Mounting Kit

Choose a mounting kit based on the Telma model chosen.

| Telma Model | Part Number |
|--|-------------|
| <ul style="list-style-type: none"> FV61-00 FV61-40 | FB940100 |
| <ul style="list-style-type: none"> FN71-65 FN71-95 FN72-20 FN72-40 | FD983100 |

step

2. Flange Kit for spot faced pinion cages

Choose a flange kit according to axle model. These kits are for spot faced axles only and include a Meritor Telma ready pinion companion flange. A special pinion cage is not needed or included. See details below.

| Axle Model | Part Number |
|----------------|-------------|
| RS160 axle | TIK02321 |
| RS180-185 axle | TIK02322 |

6. FOCAL UNIVERSAL INSTALLATIONS

6.4 DANA 060/090/105 S/D SINGLE AXLE

DANA APPLICATION APPROVAL FORM MUST BE COMPLETED AND SUBMITTED BEFORE INSTALLATION IS ALLOWED

Focal Mounting Kit

Choose a mounting kit from the table below based on the Telma model chosen and the axle. Refer to section 6.1 Universal Focal Installation for other items needed.

| Telma Model | Kit Part Number | | |
|--|-----------------|----------|----------|
| Axle Model | 060S | 090S | 105S |
| <ul style="list-style-type: none"> • FV61-00 • FV61-40 | TIK12507 | ----- | ----- |
| <ul style="list-style-type: none"> • FN71-65 • FN71-95 • FN72-20 • FN72-40 | TIK12506 | TIK12501 | TIK12500 |

This kit contains the stator carrier, companion flange and the necessary hardware to mount the Telma focal to the axle.

6.5 Dana D170/D190 Tandem Axle

DANA APPLICATION APPROVAL FORM MUST BE COMPLETED AND SUBMITTED BEFORE INSTALLATION IS ALLOWED

step

1. Telma

Choose Telma part number **DK311415**.

step

2. Focal Mounting Kit

This kit contains the stator carrier, companion flange and the necessary hardware to mount the Telma focal to the axle.

| Kit Part Number | |
|-----------------|----------|
| D170 | D190 |
| TIK12504 | TIK12505 |

6. FOCAL UNIVERSAL INSTALLATIONS

6.6 GROUPED UNIVERSAL FOCAL KITS

1. Telma Unit

The Telma unit is included in the kit
Choose the kit below based on the Torque Factor calculation.

2. Mounting kit

The focal mounting kit is included in the kit

3. Controls

Controls included may be may hand control or universal foot control for air brakes

Note 1: If low speed cutoff is desired for hand control, order speed switch P/N JC251100 for high output VSS or JC251101 for low output VSS in addition to TIK10100.

Note 2: Refer to telmausa.com technical website for general wiring diagrams.
Contact vehicle manufacturer or Telma Technical Department for specific wiring connections.

4. Transmission

Telma ABS interface JC241105 is included with the foot control kits.
JC241105 is designed for use with Allison transmission and other high output speed signals.
Caution: Some manual transmission applications with low output tail shaft mounted speed sensor require JC241103

5. U-joint size

The Telma flange yoke is included in the kit.
Choose a kit below based on the u-joint size.

Choose a kit from the table below based on the items mentioned above.

| Torque Rating | Telma Model | Meritor Axle | Controls | U-Joint Series | Transmission | Brakes Air / Hyd | Part Number |
|---------------|-------------|----------------------------|----------|----------------|--------------|------------------|-------------|
| 1600 | FN71-65 | RS145 standard small bore* | hand | 1610 | n/a | Air / Hyd | TIK10200 |
| 1600 | FN71-65 | RS160 | foot | 1710 | Allison | Air | TIK13061 |
| 2200 | FN72-20 | RS160 | foot | 1710 | Allison | Air | TIK13062 |
| 2400 | FN72-40 | RS160 | foot | 1710 | Allison | Air | TIK13063 |
| 1600 | FN71-65 | RS160 | foot | 1810 | Allison | Air | TIK13064 |
| 2200 | FN72-20 | RS160 | foot | 1810 | Allison | Air | TIK13065 |
| 2400 | FN72-40 | RS160 | foot | 1810 | Allison | Air | TIK13066 |
| 1600 | FN71-65 | RS180 | foot | 1710 | Allison | Air | TIK13067 |
| 2200 | FN72-20 | RS180 | foot | 1710 | Allison | Air | TIK13068 |
| 2400 | FN72-40 | RS180 | foot | 1710 | Allison | Air | TIK13069 |
| 1600 | FN71-65 | RS180 | foot | 1810 | Allison | Air | TIK13070 |
| 2200 | FN72-20 | RS180 | foot | 1810 | Allison | Air | TIK13071 |
| 2400 | FN72-40 | RS180 | foot | 1810 | Allison | Air | TIK13072 |

* refer to section 6.2 for details on how to identify standard small bore RS145



Date: _____

Customer number: _____

Shipment Number: _____

Order Form

| Application Data | |
|--|--|
| Vehicle year / make / model | |
| Wheelbase | |
| GVW | |
| Axle Ratio | |
| Tire Size | |
| Driveline Series | |
| Transmission make / model | |
| Axle make / model | |
| End User/Vocation | |
| Alternator/Batteries | |
| Telma Control System (foot / hand / dual) | |

| Bill to: | | | Ship to: | | |
|-----------------|-----|--|-----------------|-----|--|
| Company | | | Company | | |
| Address | | | Address | | |
| City | | | City | | |
| State | Zip | | State | Zip | |
| Phone | | | Phone | | |
| Attention | | | Attention | | |

| Customer P. O. | Date Needed | Shipment Date | Ship Via | Ordered By |
|----------------|-------------|---------------|----------|------------|
| | | | | |

| Qty | Telma Part Number | DESCRIPTION | Net price | |
|-----|-------------------|-------------|------------|-------------|
| | | | Price each | Price Total |
| | | | | |
| | | | | |
| | | | | |
| | | | | |
| | | | | |
| | | | | |
| | | | | |
| | | | | |

| | |
|--|-------|
| Special Instructions: | |
| | |
| Approval for Telma model and Installation Kit: | Date: |
| Please attach customer purchase order | |