

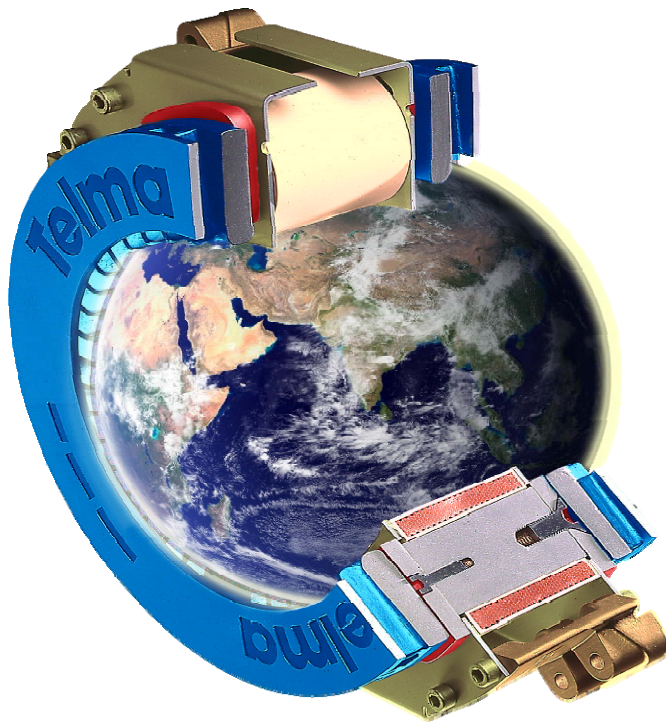

TL105088  
Telma Control Module  
(TRCM)  
Product Profile



# Telma Control Module – Overview



- **Microprocessor based**
- **8-36VDC**
- **Can be mounted in the cab or on the frame rail (IP69K)**
- **Inputs**
  - 4 inputs for pressure switches, JC120102 foot switch, or hand control switch
  - ABS Control
  - Transducer input
  - Analog speed signal
    - > NAFTA Low output magnetic pickup (sine wave amplitude less than 2V)
    - > NAFTA VSS from component ECU (typ. Square wave -amplitude 0 to system voltage.
    - > European tachograph signal
- **Outputs**
  - **4 outputs to control relay box**

Outputs are adjustable  
e.g. 1 input – 1 or two outputs turn on  
e.g. high/low setting – for given transducer voltage
  - **Onboard hardware for data link (CAN) communication. Must be programmed.**
- **Data link communication functions**
  - **Outputs to relay box turn off when:**
    - > ABS event occurs with time delay re-activation
    - > Throttle position greater than zero percent
    - > Road speed less than 2 mph (3 km/h)
  - **PC interface for settings and diagnostics**

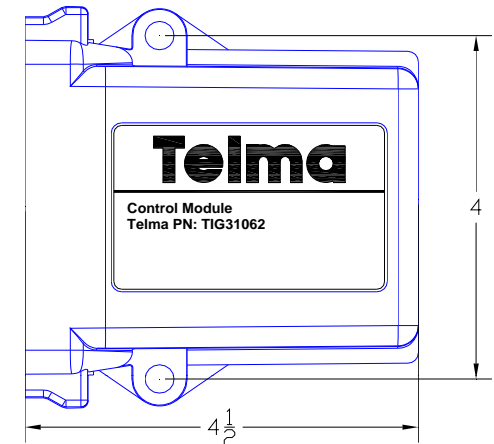

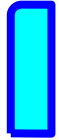

# Telma Control Module Functions and Features



CATEGORY	REQUIREMENT					
POWER SUPPLY	power (batt+) (8-36VDC)	OPERATES WITH 12 OR 24V SYSTEMS				
	ground (batt-)					
INPUTS		TYPE	INACTIVE STATE	ACTIVE STATE	LOAD	LOGIC / COMMENTS
	INPUT 1	DIGITAL	OPEN	GROUND		ACTIVE LOW=OUTPUT 1 ON / ACTIVE HIGH=OUTPUT 1&2 ON
	INPUT 2	DIGITAL	OPEN	GROUND		ACTIVE LOW=OUTPUT 2 ON / ACTIVE HIGH=OUTPUT 3 ON
	INPUT 3	DIGITAL	OPEN	GROUND		ACTIVE LOW=OUTPUT 3 ON / ACTIVE HIGH=OUTPUT 4 ON
	INPUT 4	DIGITAL	OPEN	GROUND		ACTIVE LOW=OUTPUT 4 ON / ACTIVE HIGH=OFF
	VEHICLE SPEED	ANALOG	PERIODIC			USED TO CALIBRATE SHUT OFF SPEED
	TRANSDUCER	ANALOG	1-6VDC		10mA	OUTPUTS TURN ON PROPORTIONAL TO TRANSDUCER VOLTAGE SETTINGS
	ABS CONTROL 1	DIGITAL	OPEN	GROUND		REFER TO ABS CONTROL DIAGRAM. OUTPUTS 1, 2, 3, 4 TURN OFF WHEN ABS CONTROL 1 OR 2 ACTIVE. STAGE 2, 3, 4 TURN BACK ON WITH 1 SECOND DELAY EACH WHEN ABS CONTROL 1 OR 2 CHANGES BACK TO INACTIVE (OPEN) AND DIGITAL OR TRANSDUCER INPUTS ARE STILL ACTIVE
	ABS CONTROL 2	DIGITAL	OPEN	BATT +		
	SPEED CALIBRATE	MOMENTARY	OPEN	GROUND		IN ADDITION TO DROP DOWN MENU, SHUT OFF SPEED IS SAVED BY PRESSING MOMENTARY SWITCH AT SPEED DESIRED
OUTPUTS	BAC SIGNAL 1	DIGITAL	OPEN	BATT +	6 WATTS	OUTPUT 12V OR 24V TO RELAY BOX DEPENDING ON INPUT VOLTAGE
	BAC SIGNAL 2	DIGITAL	OPEN	BATT +	6 WATTS	
	BAC SIGNAL 3	DIGITAL	OPEN	BATT +	6 WATTS	
	BAC SIGNAL 4	DIGITAL	OPEN	BATT +	6 WATTS	
DATA		READ MESSAGES FROM VEHICLE DATA LINK				
	data link high	vehicle speed is monitored on data link			outputs turn off below 2mph (3km/h)	
		engine throttle position is monitored on the data link			outputs turn off if throttle position is other than zero	
	data link low	data link is monitored for "ABS event in progress" message			outputs turn off as long as there is an "ABS event in progress" message broadcast	
		"ABS event in progress" message no longer broadcast			outputs turn on with 1 second delays on outputs 2, 3, and 4 after "ABS event in progress" is no longer broadcast. REFER TO ABS CONTROL DIAGRAM FOR DETAILS	
	serial data bi-directional (PC interface)	SERIAL PORT CONNECTION TO PC FOR DIAGNOSTICS AND SETTINGS				
	serial data ground (PC interface)					
PROTECTIONS	BATTERY INVERSION	MODULE DOES NOT FUNCTION AND SUSTAINS NO DAMAGE				
	VOLTAGE PROTECTION	MODULE SHUTS OFF AT VOLTAGE BELOW 8VDC				
	OVER CURRENT	OUTPUTS SHUT OFF WITH NO DAMAGE SUSTAINED IF PRESET CURRENT LEVELS ARE EXCEEDED				
	FAILED MODE	UNIT FAILS IN THE OFF MODE (NO OUTPUTS ON - FAIL SAFE)				
	DATA LINK COMM. FAILURE	MODULE DOES NOT FUNCTION IF COMMUNICATION IS LOST OR MESSAGES ARE NOT READ				
DIAGNOSTICS	TRANSDUCER VOLTAGE	TRANSDUCER VOLTAGE IS SHOWN				
	SPEED SIGNAL	SPEED SIGNAL COUNT IS SHOWN				
	OUTPUT CURRENT	OUTPUT CURRENT IS SHOWN				

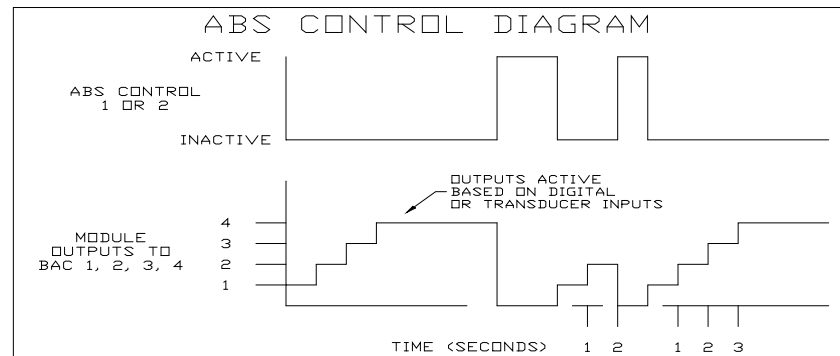

# PC INTERFACE (CONFIGURATION SCREEN)



- Connects to PC with serial port connection
- Configuration and Diagnostics can be seen and manipulated on the PC

**Telma Desktop Client**  
File Data Help

### Telma Configuration and Diagnostics Interface

**Configuration** | Diagnostics

**Edit Configuration**

Low/High:

CAN:

**Low Speed Threshold Select**

Speed (Hz):

**Transducer Voltage Setpoint**

Stage 1:

Stage 2:

Stage 3:

Stage 4:

**Current Values**

Low/High:

CAN:

**Low Speed Threshold Select**

Speed:

**Transducer Voltage Setpoint**

Stage 1:

Stage 2:

Stage 3:

Stage 4:

**Data On**  
Start

**Send All Config**  
Send

**Data Status**  
⚠

**CAN Status**  
⚠

**Telma**  
Frictionless  
Braking Systems

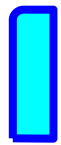

# PC INTERFACE (DIAGNOSTICS SCREEN)



- Connects to PC with serial port connection
- Configuration and Diagnostics can be seen and manipulated on the PC

The screenshot shows the 'Telma Desktop Client' window with a menu bar (File, Data, Help) and window controls. The main title is 'Telma Configuration and Diagnostics Interface'. On the left sidebar, there are sections for 'Data On' (with a 'Start' button), 'Send All Config' (with a 'Send' button), 'Data Status' (with a warning icon), and 'CAN Status' (with a warning icon). The main area has two tabs: 'Configuration' and 'Diagnostics'. The 'Diagnostics' tab is active, showing 'Stage Outputs' with a table of four rows (Input, Output, Current) and 'ABS, Speed, Transducer' data. A 'Telma Frictionless Braking Systems' logo is in the bottom left corner.

Input	Output	Current
Input 1: N/A	Output 1: N/A	Current 1: N/A
Input 2: N/A	Output 2: N/A	Current 2: N/A
Input 3: N/A	Output 3: N/A	Current 3: N/A
Input 4: N/A	Output 4: N/A	Current 4: N/A

  

Speed:	N/A	N/A
Speed Calibrate:	N/A	
Accel Pedal Pos:	N/A	
ABS:	N/A	
ABS +:	N/A	ABS -: N/A
Transducer:	N/A	

# System Diagram

Receptacle A - gry		Receptacle B - blk	
1	input 1	1	CAN H
2	input 2	2	CAN L
3	input 3	3	not used
4	input 4	4	ground
5	speed signal	5	not used
6	ground	6	CDMI RX-receive
7	batt+	7	CDMI TX-transmit
8	batt+	8	not used
9	output 1	9	transducer
10	output 2	10	speed calibrate
11	output 3	11	ABS control (-)
12	output 4	12	ABS control (+)

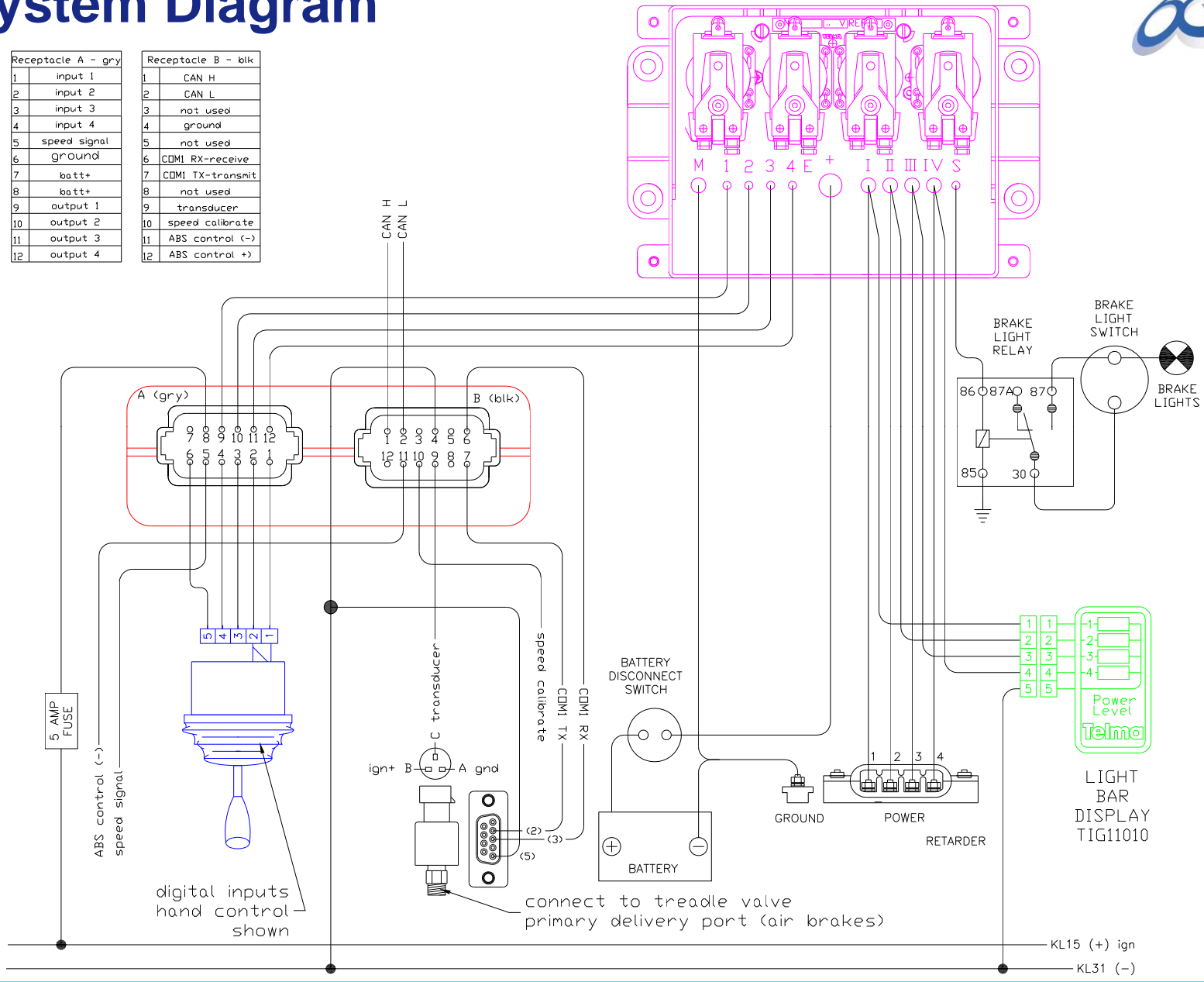

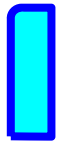

# Comparison to existing Products

