

P/N: JD331121



P/N: JE341121

Checking Relay Box Operation

1. Locate the relay box, mounted on the chassis of your vehicle, and verify which version relay box you have, (JE341121 or JD331121)
2. Check operation of box:
 - A. Verify 12v at '+' and ground at '-' or 'M' post, with no other post having ground or 12v.
 - If any other post has ground or 12v submit claim on www.telmausa.com or call 800-797-7714.
 - B. Apply 12v at post '1' and check for voltage at post 'I'.
 - If any other post other than 'I' and '+' has 12v submit claim on www.telmausa.com or call 800-797-7714.
 - C. Follow step B for all remaining posts, '2' through '4' and verifying that 'II' through 'IV' have 12v and only those corresponding posts.
3. If all 4 stages have correct output then continue to page 1 and follow Step 2 for the next step in troubleshooting.

JE341121 No Longer Available

Refer to Telma TSB TIL35031 For more information

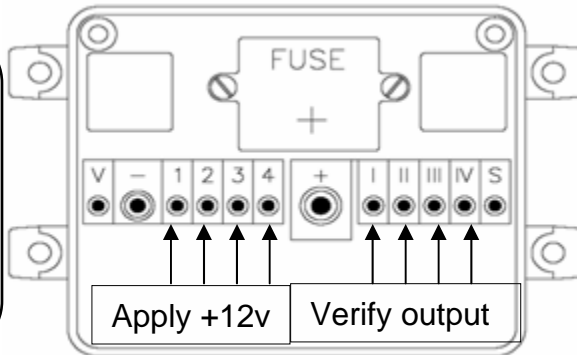

Telma P/N: JE341121

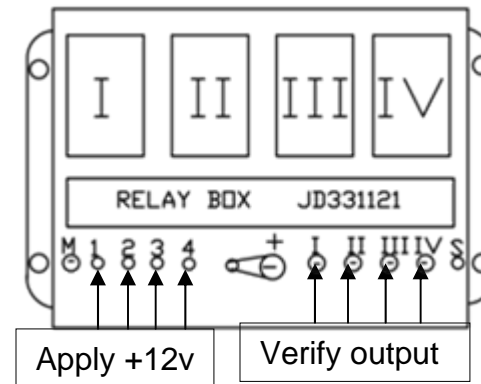

Telma P/N: JD331121

The 'E' terminal is an optional (+) terminal that is unused on most Telma systems

Telma ABS Interface Operation

1. Locate the Telma ABS Interface in the cab. Can be mounted in dash, under doghouse or in glove box, (JC241105 or JC241103).
2. Check operation of box: Verify each pin to the right for correct signal.
3. **For more help with verifying specific input signals continue to Step 3 for more troubleshooting**



Pin #	Signal	Description
1	+12v from ABS Warning Light Relay	Positive from ABS Lamp or ABS ECU, +12v with no ABS Malfunction
2	Not Connected (Telma Disable)	Only use to disable Telma, Apply ground (-) to disable Telma
4	JC241105 → >3.5 VAC	Vehicle must be moving over 2mph to get correct signal
4	JC241103 → >1 VAC	Vehicle must be moving over 2mph to get correct signal
6	+12v Output Stage 1	All other inputs correct → output +12v to relay box Post 1
7	+12v Output Stage 2	All other inputs correct → output +12v to relay box Post 2
8	+12v Output Stage 3	All other inputs correct → output +12v to relay box Post 3
9	+12v Output Stage 4	All other inputs correct → output +12v to relay box Post 4
11	(-) ABS Interface Ground	Main ABS Interface Ground from Relay box
13	+12v ABS Interface Ignition Positive	Main ABS Interface Positive, from Ignition/10A fuse
15	(-) Ground from ABS Control Relay	Ground in from ABS ECU, ground except during wheel slip
22	(-) Ground Input Stage 1	(-) Ground in from Telma control (Pressure sensors, hand control, off throttle relay)
23	(-) Ground Input Stage 2	(-) Ground in from Telma control (Pressure sensors, hand control, off throttle relay)
24	(-) Ground Input Stage 3	(-) Ground in from Telma control (Pressure sensors, hand control, off throttle relay)
25	(-) Ground Input Stage 4	(-) Ground in from Telma control (Pressure sensors, hand control, off throttle relay)

Telma Pressure Sensors

- TWO DUAL OUTPUT PRESSURE SWITCHES
 - P/N TIG31055: 3 PSI / 5 PSI SWITCH ACTIVATES TELMA STAGES 1 & 2 AT 3 PSI & 5 PSI BRAKE APPLY PRESSURE
 - P/N TIG31056: 7 PSI / 10 PSI SWITCH ACTIVATES TELMA STAGES 3 & 4 AT 7 PSI & 10 PSI BRAKE APPLY PRESSURE
- USUALLY MOUNTED IN THE CAB BUT CAN BE MOUNTED OUTSIDE WITH BOOTS
- MUST BE MOUNTED WITH SWITCHES FACING UP TO AVOID CORROSION FROM AIR SYSTEM WATER COLLECTING IN THE SWITCH
- THE AIR LINE IS CONNECTED TO BRAKE VALVE PRIMARY DELIVERY LINE

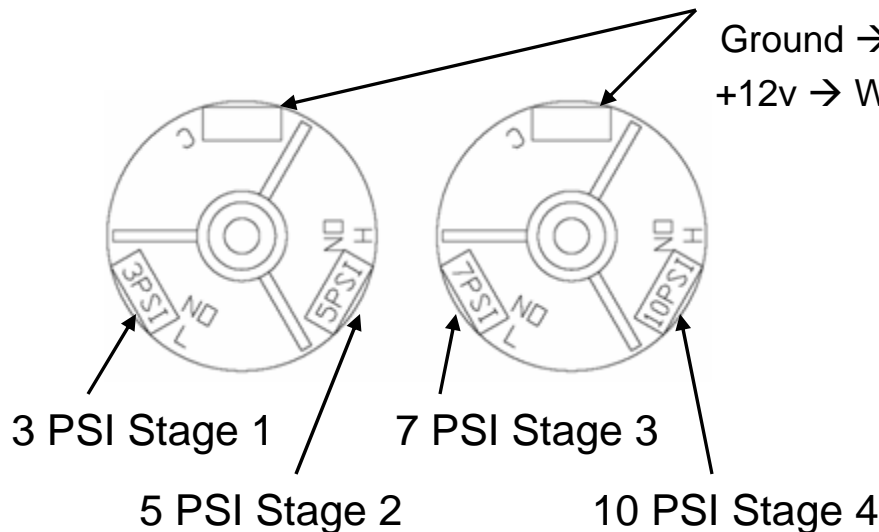

Common terminal

Ground → With ABS Interface
 +12v → Without ABS Interface

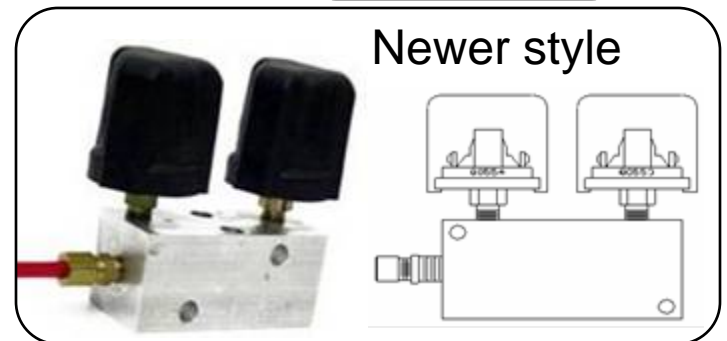
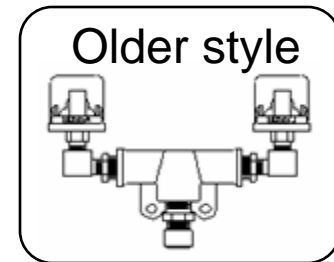

ABS Relays

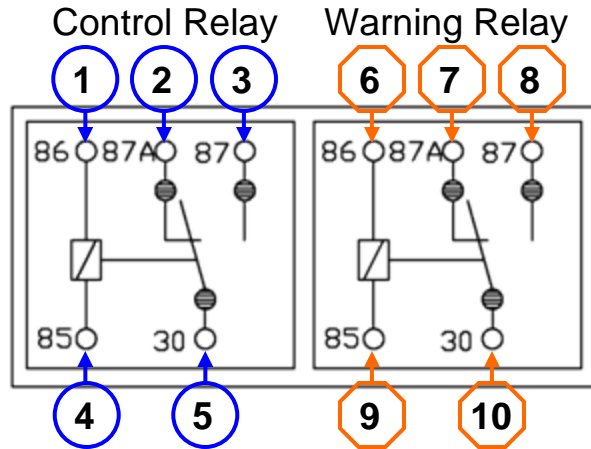

ABS Type	1	2	3	4	5	6	7	8	9	10
Bendix EC60 Cab	Ignition (+)	Pin 15 ABS Interface	Not connected	X1 Pin 17	Ground	Ignition (+)	Pin 1 ABS Interface	Not connected	X1 Pin 18	IGN (+) from 10A Fuse
Bendix EC60 Frame	Ignition (+)	Pin 15 ABS Interface	Not connected	X1 Pin 10	Ground	ABS Lamp (-)	Pin 1 ABS Interface	Not connected	ABS Lamp (+)	IGN (+) from 10A Fuse
Wabco D Cab	Ignition (+)	Pin 15 ABS Interface	Not connected	Pin 14 of 15-pin connector	Ground	ABS Lamp (-)	Pin 1 ABS Interface	Not connected	Ignition (+)	IGN (+) from 10A Fuse
Wabco D&E Frame*	X1-Grey pin 2	Pin 15 ABS Interface	Not connected	Pin 87 of additional relay	Ground	ABS Lamp (-)	Pin 1 ABS Interface	Not connected	ABS Lamp (+)	IGN (+) from 10A Fuse

*Needs an additional relay <3 feet from Wabco Frame ECU, see wiring diagram for more information
 NOTE: Do not connect Warning Lamp Relay if system is multiplexed

VSS From Transmission



- Telma is disabled while vehicle is under 2 mph
- Signal comes from transmission Vehicle Speed Sensor or transmission ECU
- Inputs in to:
 - ABS Interface Pin #4
 - Or: Telma Speed switch Pin #1 of 4 pin connector if signal is generated by an active magnetic sensor (>1 VAC output)
 - Or: Telma Speed Switch Pin #3 of 4 pin connector if signal is generated by a passive magnetic sensor (>3.5 VAC output)

Transmission	Output pin of transmission ECU	ABS Interface type
Allison World (1000, 2000, 3000, 4000 series) with GEN 4 Controls	Wire 125 or Pin #25	Telma P/N: JC241105
Allison World (1000, 2000, 3000, 4000 series) with WTECIII Controls	Grey Pin #20 or Black Pin #30	Telma P/N: JC241105
Manual transmission or Allison Hydraulic	Vehicle speed sensor on tail shaft of transmission	Telma P/N: JC241103
Ford E350/E450	Grey/Black Wire Circuit 679 Marked: AFT STD (Gas) / VSO (Diesel)	Speed Switch: P/N JC251100 (>3.5 VAC)

For more information and to obtain

- Wiring diagrams
- Warranty Procedures
- Telma Specifications
- Troubleshooting Videos
- And much more

Please visit our Technical Website at

www.telmausa.com

Telma Retarder Inc
1501 Morse Ave.
Elk Grove Village, IL 60007
800-797-7714